

Large Bore High Pressure Hydraulic Cylinders

Series 3H

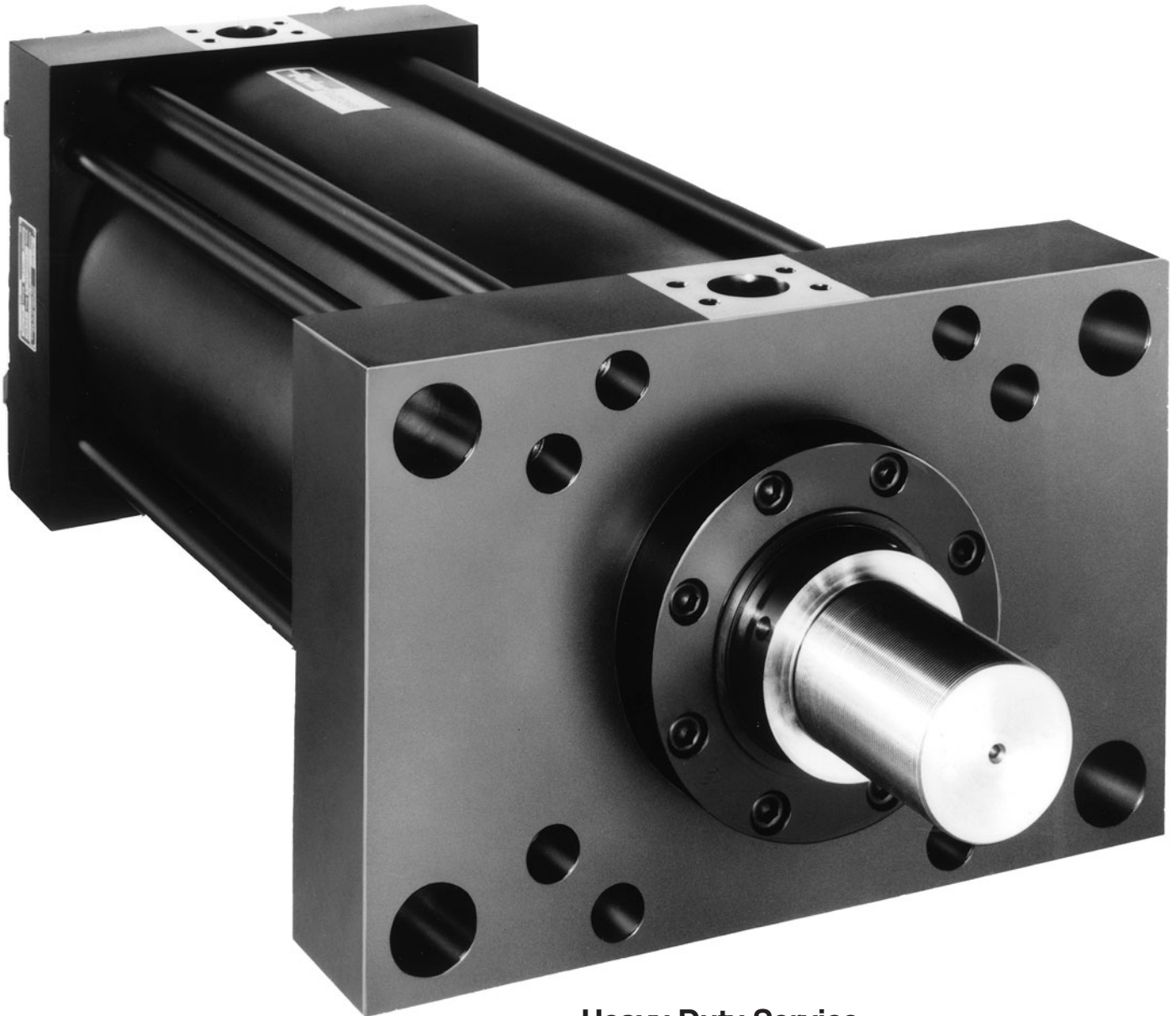

Heavy Duty Service —
Industrial Tie-Rod Construction

- Nominal Pressure — 3000 PSI
- Thirteen Standard Mounting Styles

For Cylinder Division Plant Locations – See Page II.

The large bore, high pressure hydraulic cylinder Parker designed to meet your needs

In the Series 3H cylinder you get unmatched reliability, performance, and innovative design features to help increase productivity and reduce your operating costs.

Parker's externally removable bolt-on gland assembly makes preventive maintenance fast...and easy! You **do not** have to disassemble the cylinder, loosen the tie rod nuts, or remove the long cast iron rod bearing to replace the patented Polypak® double bevel lipseal and double service Wiperseal. The ruggedly constructed gland assembly includes the ultimate in sealing for extra heavy duty applications in most any industry. The high pressure large bore Series 3H hydraulic cylinder also includes

the innovative anti-extrusion body end seal design...where the heads and caps are specially machined **to prevent** extrusion of the body end seals and insure against leakage — PLUS... every cylinder is individually tested before it leaves our plant.

For quick delivery, the Series 3H is available to you from our regional plant system. Select **genuine** Parker cylinder replacement parts are stocked by over 130 local Parker distributors from coast-to-coast.

See pages 90 and 91 for all the features that make the Parker Series 3H your best choice for all your large bore high pressure hydraulic cylinder applications...

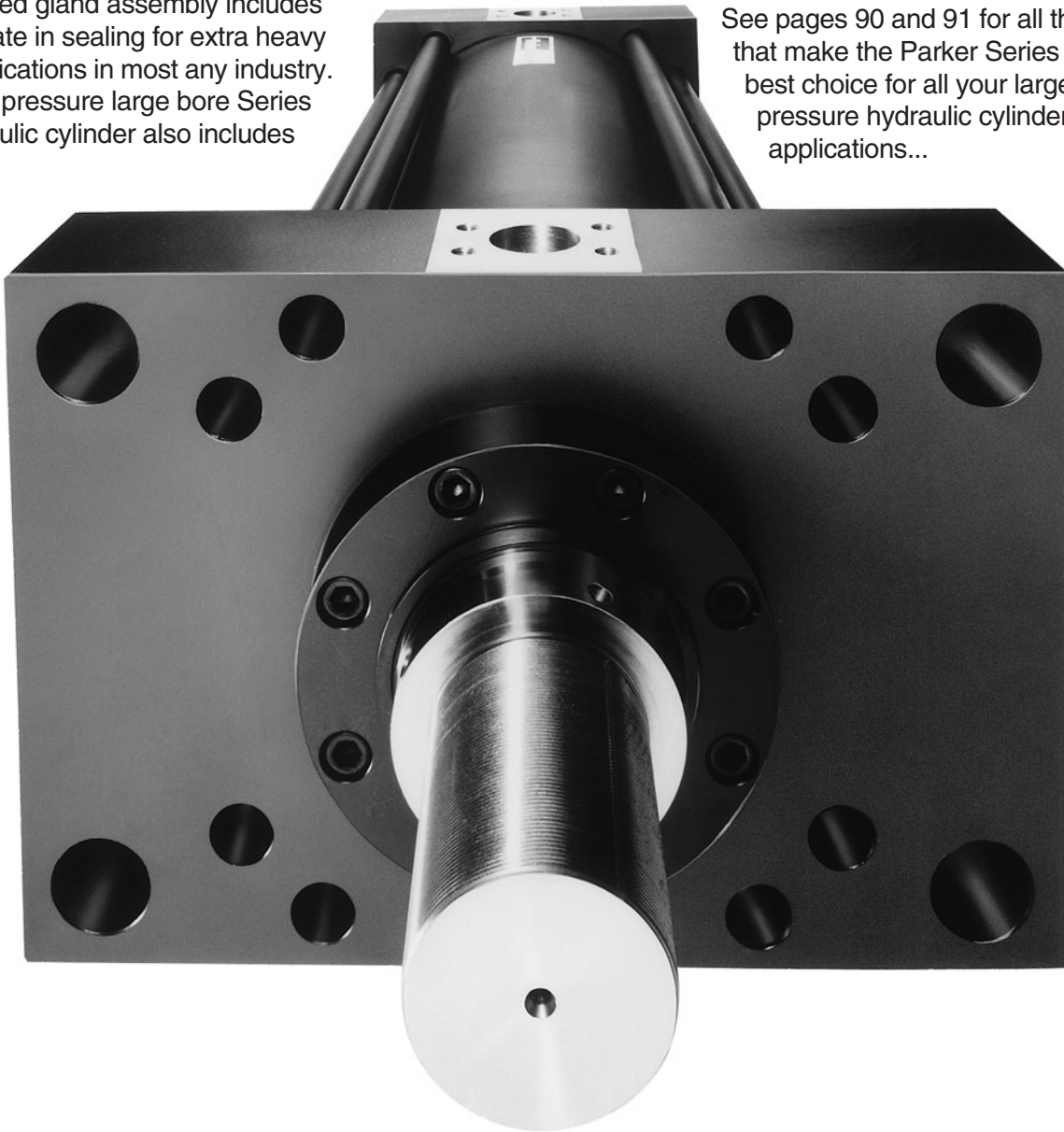

For additional information – call your local Parker Cylinder Distributor.

Series 3H Large Bore High Pressure Hydraulic Cylinders

Specifications/
Mountings
Large Bore Sizes

Standard Specifications

- Heavy Duty Service
- Standard Construction – Square Head – Tie Rod Design
- Nominal Pressure – 3000 PSI*
- Standard Fluid – Hydraulic Oil
- Standard Temperature -10°F. to +165°F.**
- Bore Sizes – 10" through 20" (Larger sizes available)

- Piston Rod Diameter – 4 1/2" through 10"
- Mounting Styles – Ten standard styles at various application ratings
- Strokes – Available in any practical stroke length
- Cushions – Optional at either end or both ends of stroke
- Rod Ends – Two Standard Choices – Specials to Order

In line with our policy of continuing product improvement, specifications in this catalog are subject to change.

*If hydraulic operating pressure exceeds 3000 PSI, send application data for engineering evaluation and recommendation. See section C, page 118 for actual design factors.

** See section C, page 83 for higher temperature service.

Available Mounting Styles

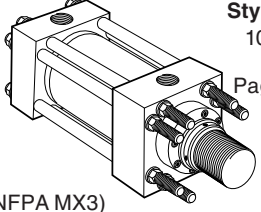
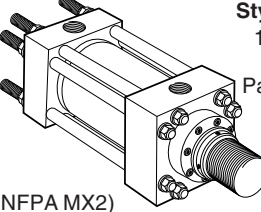
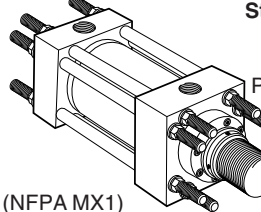
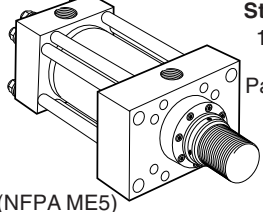
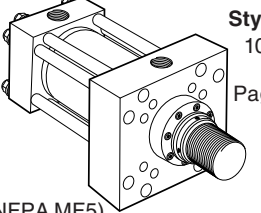
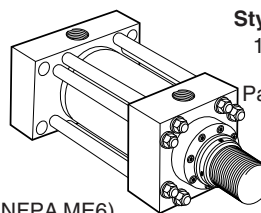
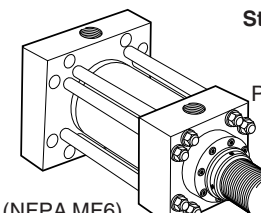
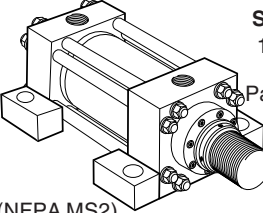
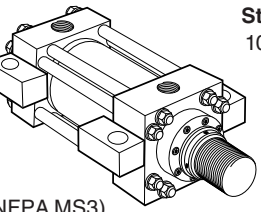
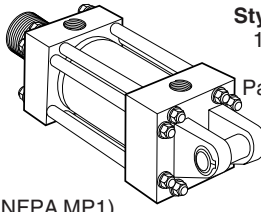
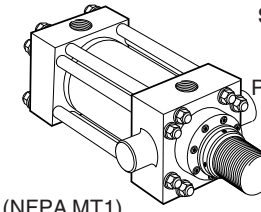
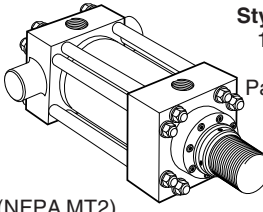
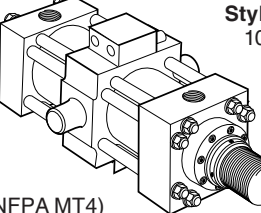
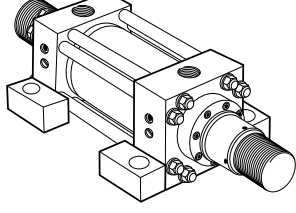
<p>Tie Rods Extended Head End</p>  <p>Style TB 10"-14" Bore, Page 92</p> <p>(NFPA MX3)</p>	<p>Tie Rods Extended Cap End</p>  <p>Style TC 10"-14" Bore, Page 92</p> <p>(NFPA MX2)</p>	<p>Tie Rods Extended Both Ends</p>  <p>Style TD 10"-14" Bore, Page 92</p> <p>(NFPA MX1)</p>	<p>Head Rectangular</p>  <p>Style JJ 10"-20" Bore, Page 94</p> <p>(NFPA ME5)</p>
<p>Head Square Flange</p>  <p>Style JB 10"-20" Bore, Page 94</p> <p>(NFPA MF5)</p>	<p>Cap Rectangular</p>  <p>Style HH 10"-20" Bore, Page 96</p> <p>(NFPA ME6)</p>	<p>Cap Square Flange</p>  <p>Style HB 10"-20" Bore, Page 96</p> <p>(NFPA MF6)</p>	<p>Side Lug</p>  <p>Style C 10"-14" Bore, Page 96</p> <p>(NFPA MS2)</p>
<p>Centerline Lugs</p>  <p>Style E 10"-14" Bore, Page 96</p> <p>(NFPA MS3)</p>	<p>Cap Fixed Clevis</p>  <p>Style BB 10"-20" Bore, Page 98</p> <p>(NFPA MP1)</p>	<p>Head Trunnion</p>  <p>Style D 10"-14" Bore, Page 98</p> <p>(NFPA MT1)</p>	<p>Cap Trunnion</p>  <p>Style DB 10"-14" Bore, Page 98</p> <p>(NFPA MT2)</p>
<p>Intermediate Fixed Trunnion</p>  <p>Style DD 10"-20" Bore, Page 98</p> <p>(NFPA MT4)</p>	<p>Double Rod Cylinders</p>  <p>Style KTB Shown</p> <p>Most of the above illustrated mounting styles are available in double rod cylinders. See Catalog Page 100.</p>		

B

For Cylinder Division Plant Locations – See Page II.

These innovative design features make Parker Series 3H your best choice... for all your large bore high pressure hydraulic cylinder applications...

Primary Seal – Polypak® double-bevel lip design combines ease of installation with rugged construction. The ultimate seal in extra heavy duty applications. Completely self-compensating and self-relieving to withstand pressure variations and conform to mechanical deflection that may occur.

Secondary Seal – Double-Service Wiperseal® (Patent #2907596) – wipes clean any oil film adhering to the rod on the extend stroke and cleans the rod on the return stroke.

Bolt-On Rod Gland Assembly – Externally removable without cylinder disassembly. Long cast-iron bearing surface is inboard of the seals, assuring positive lubrication from within the cylinder. An “O” ring is used as a seal between gland and head.

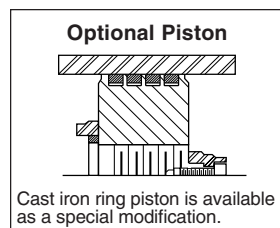

Steel Head – Bored and grooved to provide concentricity for mating parts.

Alloy Steel Tie Rod Nuts – With hardened washer.

High Strength Tie Rods – Made from 100,000 PSI minimum yield steel with rolled threads for added strength.

End Seals – Pressure-actuated cylinder body-to-head and cap “O” rings and back-up washers.

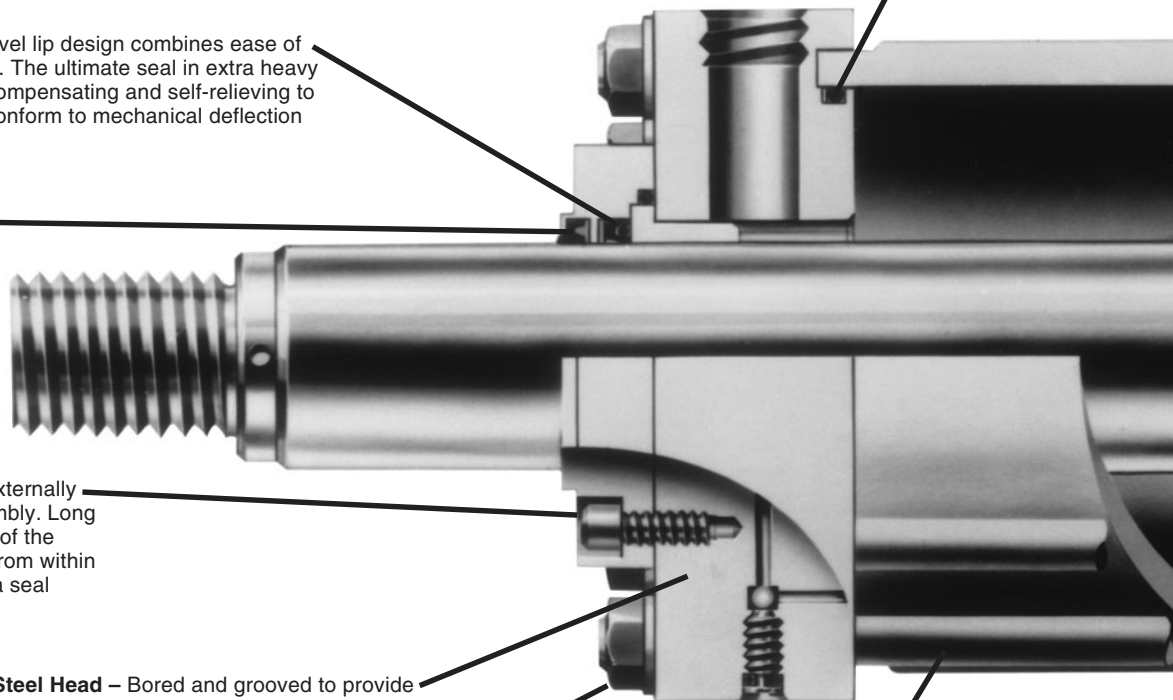

Parker’s Exclusive Stepped floating cushions combine the best features of known cushion technology.

Deceleration devices or built-in “cushions” are optional and can be supplied at head end, cap end, or both ends without change in envelope or mounting dimensions.

Standard straight or tapered cushions have been used in industrial cylinders over a very broad range of applications. Parker research has found that both designs have limitations. As a result, Parker has taken a new approach in cushioning of industrial hydraulic cylinders and for specific load and velocity conditions have been able to obtain deceleration curves that come very close to the ideal. The success lies in a stepped sleeve or spear concept where the steps are calculated to approximate theoretical orifice areas curves. In the cushion performance chart, pressure traces show the results of typical orifice flow conditions. Tests of a three-step sleeve or spear show three pressure pulses coinciding with the steps. The deceleration cushion plunger curves shape comes very close to being theoretical, with the exception of the last 1/2" of travel. This is a constant shape in order to have some flexibility in application. The

stepped cushion design shows reduced pressure peaks for most load and speed conditions, with comparable reduction of objectionable stopping forces being transmitted to the load and the support structure.

The Series 3H design incorporates the longest cushion sleeve and cushion spear that can be provided in the standard envelope without decreasing the rod bearing and piston bearing lengths.

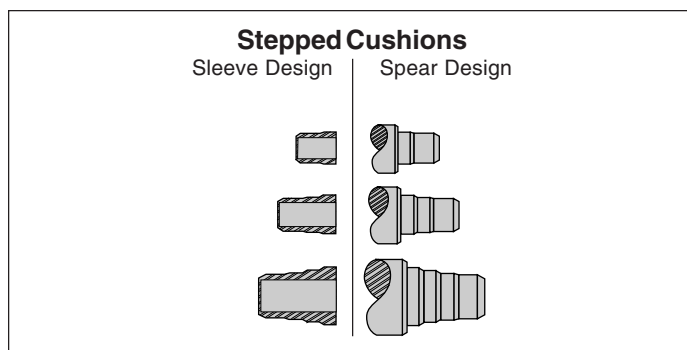

For additional information – call your local Parker Cylinder Distributor.

Piston Rod – Hard chrome-plated and polished for maximum seal and rod bearing life. Two standard thread styles. Rod end is supplied with spanner wrench holes.

Hi-Load Piston Seals – Are standard.

Align-A-Groove® – (Patent #3043639) – A $\frac{3}{16}$ " wide surface machined at each end of the cylinder body. Makes precise mounting quick and easy.

Ports – SAE O-ring straight thread ports are standard.

Optional Ports

Ports – SAE straight thread ports or NPTF (Dry Seal Pipe Ports) are available for an extra charge.

Seals – Buna-N (Nitrile) seals are standard.

Fluorocarbon Seals – Optional at extra charge.

One-Piece Nodular Iron Piston – The wide piston surface contacting cylinder bore reduces bearing loads. One piece design is piloted to piston rod assuring concentricity. Piston is locked with set screw. Anaerobic adhesive and peening of set screw locks and seals piston to rod.

Steel Cap – Bored and grooved to provide concentricity for mating parts.

The Cylinder Body – Heavy-wall steel tubing is honed to a 15 RMS micro finish bore providing a wear surface for long lasting piston bearing and seal life.

Adjustable Floating Stepped Cushions – For maximum performance. Economical and flexible for even the most demanding applications. Provides superior performance in reducing shock. Cushions are optional and can be supplied at head end, cap end, or both ends without change in envelope or mounting dimensions.

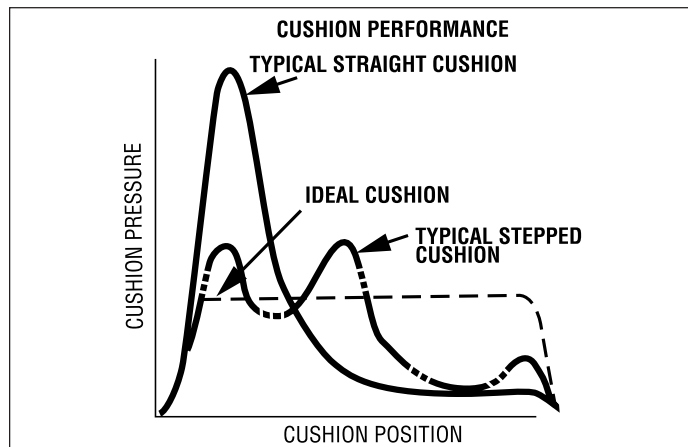

- (1) When a cushion is specified at the head end:
- a. A stepped sleeve is furnished on the piston rod assembly.
 - b. A needle valve is provided that is flush with the side of the head even when wide open. It may be identified by the fact that it is

- socket-keyed. It is located on side number 3, in all mounting styles except C. In this style it is located on side number 2.
 - c. A springless check valve is provided that is also flush with the side of the head and is mounted on the same side as the needle valve except on mounting style C, where it is mounted on side number 2, next to the needle valve. It may be identified by the fact that it is slotted.
 - d. The check and needle valves are interchangeable in the head.
- (2) When a cushion is specified at the cap end:
- a. A cushion-stepped spear is provided on the piston rod.
 - b. A socket-keyed needle valve is provided that is flush with the side of the cap when wide open. It is located on side number 3 in all mounting styles except C. In this style it is located on side number 2.
 - c. A springless check valve is provided that is also flush with the side of the cap and is mounted on the same side as the needle valve except on mounting style C, where it is mounted on side number 2, next to the needle valve.
 - d. The check and needle valves are interchangeable in the cap.

For Cylinder Division Plant Locations – See Page II.



B

**Tie Rod Mountings
Large Bore Sizes**

Series 3H Large Bore High Pressure Hydraulic Cylinders

**Tie Rods Extended Head End
Style TB
(NFFA Style MX3)**

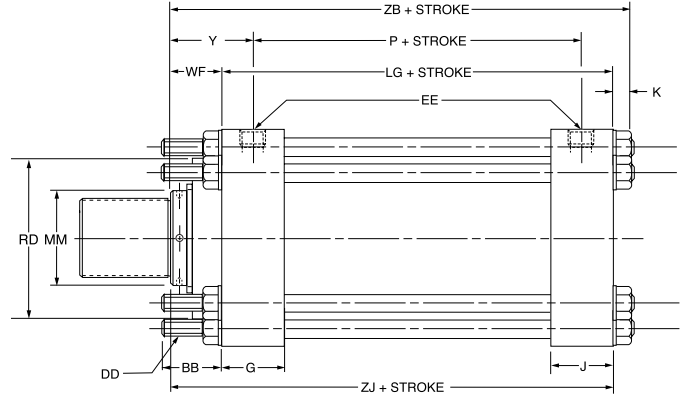
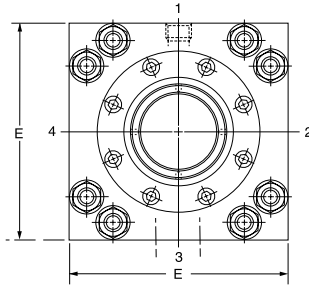
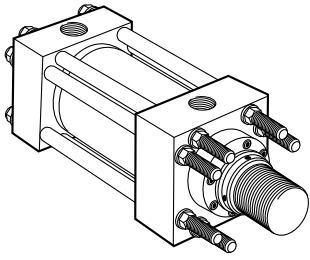

**Tie Rods Extended Cap End
Style TC
(NFFA Style MX2)**

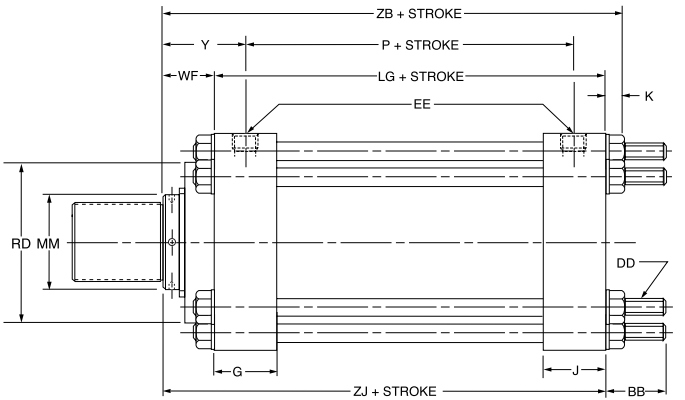
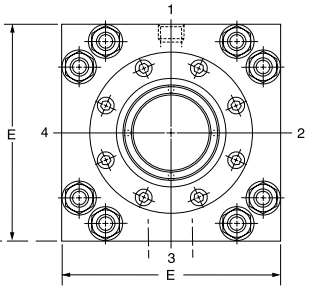
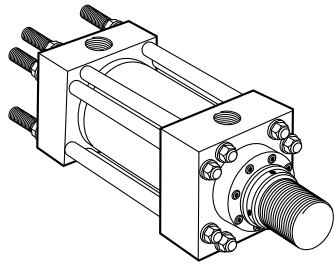

**Tie Rods Extended Both Ends
Style TD
(NFFA Style MX1)**

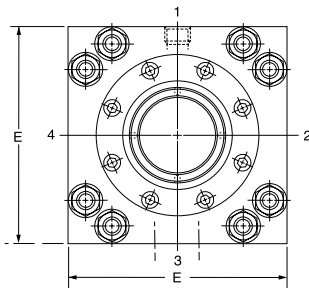
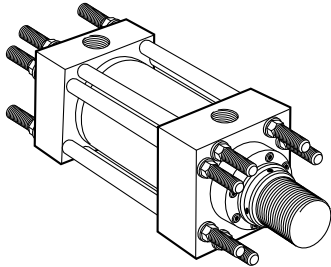

Basic Mounting (T) — Not shown is no tie rod extended and can be supplied upon request.

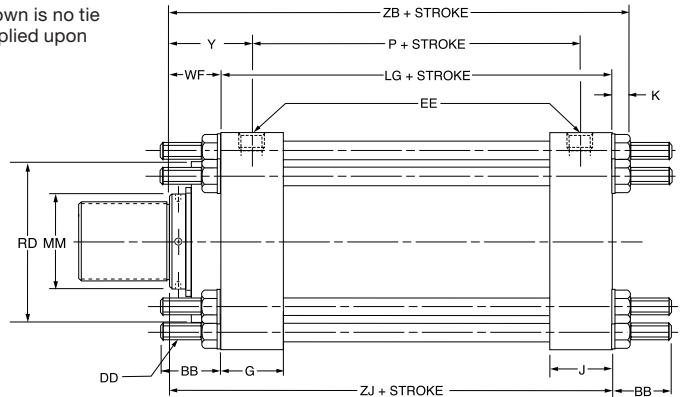

Rod End Dimensions — see table 2

**Thread Style 4
(NFFA Style SM)
Small Male**

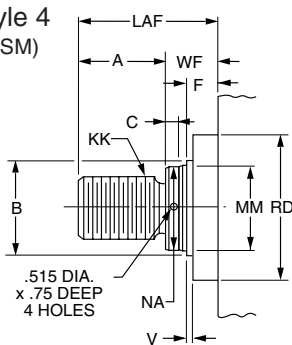

If rod end is not specified, Style 4 will be furnished.

**Thread Style 9
(NFFA Style SF)
Small Female**

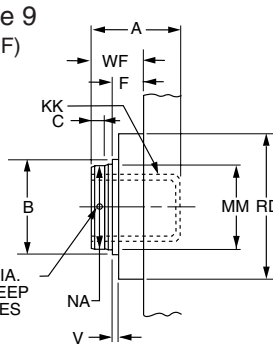

Use Style 9 for applications where female rod ends are required.

**Special Thread
Style 3**

Special thread, extension, rod eye, blank, etc., are also available.

To order, specify "Style 3" and give desired dimensions for KK, A and LAF or WF. If otherwise special, furnish dimensional sketch.

For additional information — call your local Parker Cylinder Distributor.

Series 3H Large Bore High Pressure Hydraulic Cylinders

Tie Rod Mountings
Large Bore Sizes

Table 1—Envelope and Mounting Dimensions

Bore	BB	DD	E	EE* NPTF	EE† S.A.E. FLANGE PORT	EE** S.A.E. STRAIGHT THREAD	G	J	K	RA	RB	RC	RR	Add Stroke	
														LG	P
10	4 1/8	1 1/8-12	12 5/8	2	2	24	3 11/16	3 11/16	1 9/32	5.291	3.775	—	2 1/8	12 1/8	8 1/2
12	4 1/2	1 1/4-12	14 7/8	2 1/2	2 1/2	24	4 7/16	4 7/16	1 13/32	6.270	4.555	—	2 3/8	14 1/2	10 1/8
14	4 1/2	1 1/4-12	17 1/8	2 1/2	2 1/2	24	4 7/8	4 7/8	1 13/32	7.485	6.143	4.409	2 1/4	15 5/8	10 7/8

* NPTF ports are available for an extra charge.

† Optional SAE flange ports may be specified – flange to be supplied by customer. See Table 4 for flange port pattern dimensions.

** SAE straight thread ports are standard and are indicated by port number.

**Table 3—
Envelope and
Mounting
Dimensions**

Table 2—Rod Dimensions

Bore	Rod No.	Rod Dia. MM	Thread KK	Rod Extensions and Pilot Dimensions									Add Stroke		
				A	+0.000 -0.005 B	C	F	LAF	NA	RD	V	WF	Y	ZB	ZJ
10	1	4 1/2	3 1/4-12	4 1/2	5.249	1	1 15/16	7 7/16	4 3/8	8 1/4	1/4	2 15/16	4 3/4	16 11/32	15 1/16
	2	7	5-12	7	7.999	1	1 15/16	10 1/2	6 7/8	10 1/2	3/8	3 1/2	5 5/16	16 29/32	15 5/8
	3	5	3 1/2-12	5	5.749	1	1 15/16	8 3/16	4 7/8	8 7/8	1/4	3 3/16	5	16 19/32	15 5/16
	4	5 1/2	4-12	5 1/2	6.249	1	1 15/16	8 11/16	5 3/8	9 3/8	1/4	3 3/16	5	16 19/32	15 5/16
12	1	5 1/2	4-12	5 1/2	6.249	1	1 15/16	8 11/16	5 3/8	9 3/8	1/4	3 3/16	5 3/8	19 3/32	17 11/16
	2	8	5 3/4-12	8	8.999	1	1 15/16	12	7 7/8	12 1/2	3/8	4	6 3/16	19 29/32	18 1/2
	3	7	5-12	7	7.999	1	1 15/16	10 1/2	6 7/8	10 1/2	3/8	3 1/2	5 11/16	19 13/32	18
14	1	7	5-12	7	7.999	1	1 15/16	10 1/2	6 7/8	10 1/2	3/8	3 1/2	5 7/8	20 17/32	19 1/8
	2	10	7 1/4-12	10	10.999	1	1 15/16	14 1/2	9 7/8	14 1/2	3/8	4 1/2	6 7/8	21 17/32	20 1/8
	3	8	5 3/4-12	8	8.999	1	1 15/16	12	7 7/8	12 1/2	3/8	4	6 3/8	21 1/32	19 5/8

Table 4—Optional SAE Flange Port Pattern

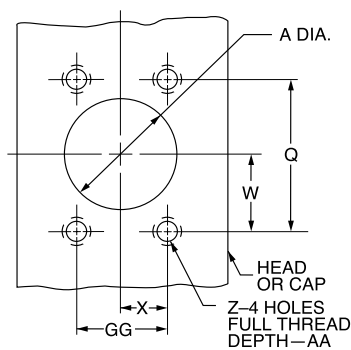

Nom. Flange Size	A	Q	GG	W	X	Z-THD UNC-2B	AA Min.	SAE
1 1/2	1.50	2.750	1.406	1.38	0.70	1/2-13	1.06	24
2	2.00	3.062	1.688	1.53	0.84	1/2-13	1.06	32
2 1/2	2.50	3.500	2.000	1.75	1.00	1/2-13	1.19	40
3	3.00	4.188	2.438	2.09	1.22	5/8-11	1.19	48

**Table 5—Tie Rod Information
see table 1 for dimensions**

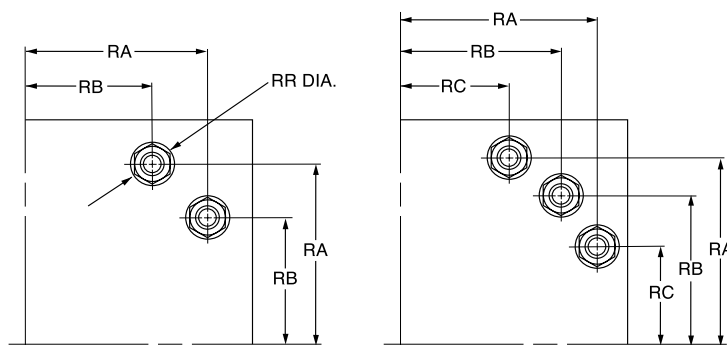

10", 12" Bores, 8 Tie Rods

14" Bores, 12 Tie Rods

For Cylinder Division Plant Locations – See Page II.



**Head Rectangular and Square Mountings
Large Bore Sizes**

Series 3H Large Bore High Pressure Hydraulic Cylinders

**Head Rectangular Mounting
Style JJ (10"-14" Bore)
(NFPA Style ME5)**

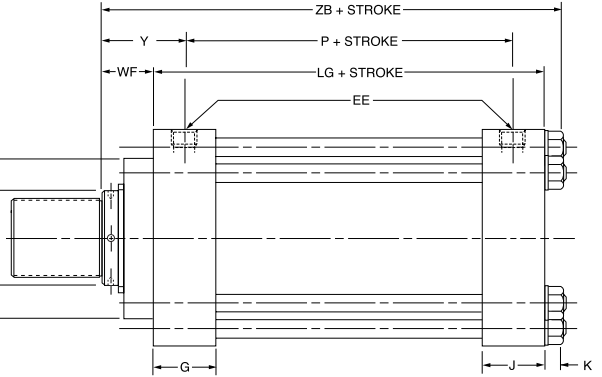
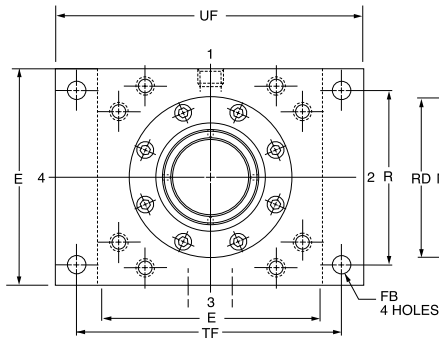
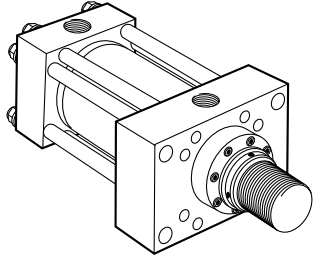

**Head Rectangular Mounting
Style JJ (16"-20" Bore)
(NFPA Style ME5)**

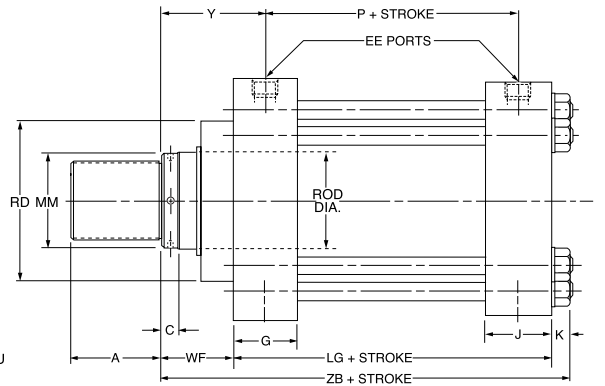
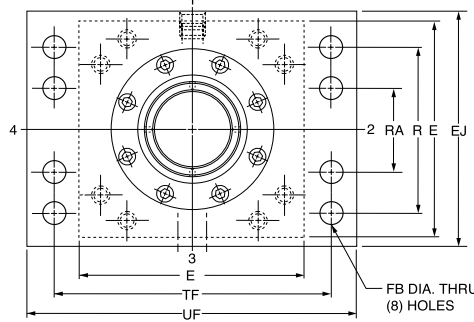
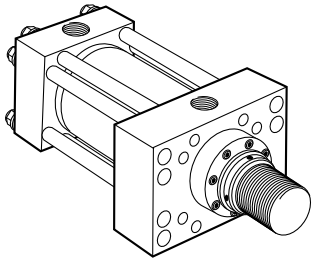

**Head Square Flange Mounting
Style JB
(NFPA Style MF5)**

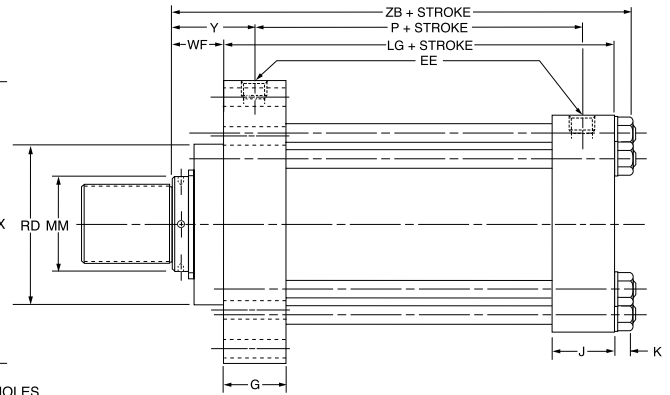
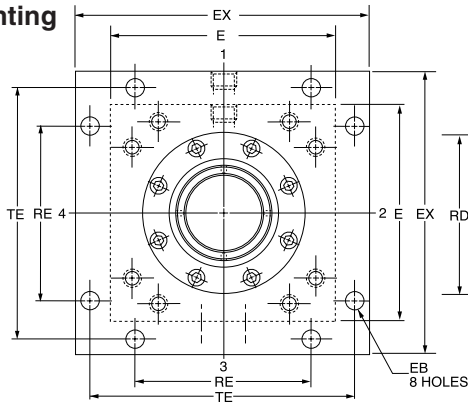
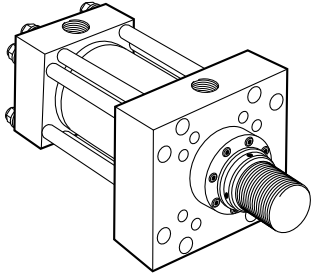

Rod End Dimensions — see table 2

**Thread Style 4
(NFPA Style SM)
Small Male**

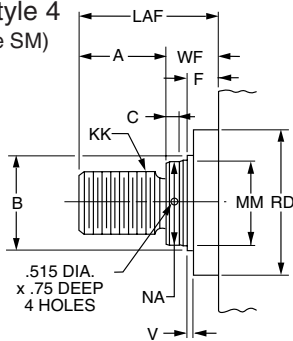

If rod end is not specified, Style 4 will be furnished.

**Thread Style 9
(NFPA Style SF)
Small Female**

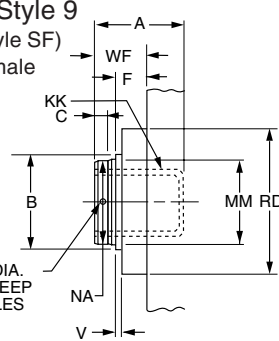

Use Style 9 for applications where female rod ends are required.

**Special Thread
Style 3**

Special thread, extension, rod eye, blank, etc., are also available.

To order, specify "Style 3" and give desired dimensions for KK, A and LAF or WF. If otherwise special, furnish dimensional sketch.

For additional information – call your local Parker Cylinder Distributor.

Series 3H Large Bore High Pressure Hydraulic Cylinders

Head Rectangular and
Square Mountings
Optional Flange Ports
Tie Rod Information

Table 1—Envelope and Mounting Dimensions

Bore	E	EB	EE* NPTF	EE† S.A.E. FLANGE PORT	EE** S.A.E. STRAIGHT THREAD	EX	FB	G	J	K	R	RE	TE	TF	UF	Add Stroke	
																LG	P
10	12 ⁵ / ₈	15 ¹ / ₁₆	2	2	24	16 ⁵ / ₈	11 ³ / ₁₆	31 ¹ / ₁₆	31 ¹ / ₁₆	19 ⁹ / ₃₂	9.62	9.89	14.13	157 ⁷ / ₈	19	12 ¹ / ₈	8 ¹ / ₂
12	14 ⁷ / ₈	19 ¹ / ₁₆	2 ¹ / ₂	2 ¹ / ₂	24	19 ³ / ₄	2 ¹ / ₁₆	47 ¹ / ₁₆	47 ¹ / ₁₆	11 ³ / ₃₂	11.45	11.75	16.79	181 ¹ / ₂	22	14 ¹ / ₂	10 ¹ / ₈
14	17 ¹ / ₈	11 ³ / ₁₆	2 ¹ / ₂	2 ¹ / ₂	24	21 ³ / ₄	2 ⁵ / ₁₆	47 ⁷ / ₈	47 ⁷ / ₈	11 ³ / ₃₂	13.26	12.90	18.43	21	25	15 ⁵ / ₈	107 ⁷ / ₈

Table 1A—Envelope and Mounting Dimensions

Bore	E	EB	EE (SAE)	EE (FLANGE)	EJ	EX	FB	G	J	K	R	RA	RE	TE	TF	UF	Add Stroke	
																	LG	P
16	19	11 ³ / ₁₆	24	3	20	24 ¹ / ₂	11 ³ / ₁₆	57 ⁷ / ₈	57 ⁷ / ₈	129 ²⁹ / ₃₂	15 ¹ / ₂	8	15.28	21.03	21	24 ¹ / ₂	18 ¹ / ₈	12 ¹ / ₈
18	22	21 ¹ / ₁₆	24	3	23	26 ¹ / ₂	2 ¹ / ₁₆	67 ⁷ / ₈	67 ⁷ / ₈	129 ²⁹ / ₃₂	18	7 ¹ / ₄	16.45	22.65	24 ¹ / ₄	28 ¹ / ₄	21 ¹ / ₈	15 ¹ / ₈
20	24	21 ¹ / ₁₆	24	3	25	29	2 ¹ / ₁₆	77 ⁷ / ₈	77 ⁷ / ₈	129 ²⁹ / ₃₂	20	8	18.07	24.87	26 ¹ / ₂	30 ¹ / ₂	23 ⁵ / ₈	17 ⁵ / ₈

* NPTF ports are available at an extra charge.

† Optional SAE flange ports may be specified – flange to be supplied by customer. See Table 4 for flange port pattern dimensions.

** SAE straight thread ports are standard and are indicated by port number.

Table 2—Rod Dimensions

Bore	Rod No.	Rod Dia. MM	Thread KK	Rod Extensions and Pilot Dimensions											Add Stroke
				A	+0.000 -0.005 B	C	F	LAF	NA	RD	V	WF	Y	ZB	
10	1	4 ¹ / ₂	3/4-12	4 ¹ / ₂	5.249	1	1 ¹⁵ / ₁₆	7 ⁷ / ₁₆	4 ³ / ₈	8 ¹ / ₄	1/4	2 ¹⁵ / ₁₆	4 ³ / ₄	16 ¹¹ / ₃₂	
	2	7	5-12	7	7.999	1	1 ¹⁵ / ₁₆	10 ¹ / ₂	6 ⁷ / ₈	10 ¹ / ₂	3/8	3 ¹ / ₂	5 ⁵ / ₁₆	16 ²⁹ / ₃₂	
	3	5	3/2-12	5	5.749	1	1 ¹⁵ / ₁₆	8 ³ / ₁₆	4 ⁷ / ₈	8 ⁷ / ₈	1/4	3 ³ / ₁₆	5	16 ¹⁹ / ₃₂	
	4	5 ¹ / ₂	4-12	5 ¹ / ₂	6.249	1	1 ¹⁵ / ₁₆	8 ¹¹ / ₁₆	5 ³ / ₈	9 ³ / ₈	1/4	3 ³ / ₁₆	5	16 ¹⁹ / ₃₂	
12	1	5 ¹ / ₂	4-12	5 ¹ / ₂	6.249	1	1 ¹⁵ / ₁₆	8 ¹¹ / ₁₆	5 ³ / ₈	9 ³ / ₈	1/4	3 ³ / ₁₆	5 ³ / ₈	19 ³ / ₃₂	
	2	8	5 ³ / ₄ -12	8	8.999	1	1 ¹⁵ / ₁₆	12	7 ⁷ / ₈	12 ¹ / ₂	3/8	4	6 ³ / ₁₆	19 ²⁹ / ₃₂	
	3	7	5-12	7	7.999	1	1 ¹⁵ / ₁₆	10 ¹ / ₂	6 ⁷ / ₈	10 ¹ / ₂	3/8	3 ¹ / ₂	5 ¹¹ / ₁₆	19 ¹³ / ₃₂	
14	1	7	5-12	7	7.999	1	1 ¹⁵ / ₁₆	10 ¹ / ₂	6 ⁷ / ₈	10 ¹ / ₂	3/8	3 ¹ / ₂	5 ⁷ / ₈	20 ¹⁷ / ₃₂	
	2	10	7 ¹ / ₄ -12	10	10.999	1	1 ¹⁵ / ₁₆	14 ¹ / ₂	9 ⁷ / ₈	14 ¹ / ₂	3/8	4 ¹ / ₂	6 ⁷ / ₈	21 ¹⁷ / ₃₂	
	3	8	5 ³ / ₄ -12	8	8.999	1	1 ¹⁵ / ₁₆	12	7 ⁷ / ₈	12 ¹ / ₂	3/8	4	6 ³ / ₈	21 ¹ / ₃₂	
16	1	8	5 ³ / ₄ -12	8	8.999	1	1 ¹⁵ / ₁₆	12	7 ⁷ / ₈	12 ¹ / ₂	3/8	4	7	24 ¹ / ₃₂	
	3	9	6 ¹ / ₂ -12	9	9.999	1	1 ¹⁵ / ₁₆	13 ¹ / ₄	8 ⁷ / ₈	13 ¹ / ₂	3/8	4 ¹ / ₄	7 ¹ / ₄	24 ⁹ / ₃₂	
	4	10	7 ¹ / ₄ -12	10	10.999	1	1 ¹⁵ / ₁₆	14 ¹ / ₂	9 ⁷ / ₈	14 ¹ / ₂	3/8	4 ¹ / ₂	7 ¹ / ₂	24 ¹⁷ / ₃₂	
18	1	9	6 ¹ / ₂ -12	9	9.999	1	1 ¹⁵ / ₁₆	13 ¹ / ₄	8 ⁷ / ₈	13 ¹ / ₂	3/8	4 ¹ / ₄	7 ¹ / ₄	27 ⁹ / ₃₂	
	3	10	7 ¹ / ₄ -12	10	10.999	1	1 ¹⁵ / ₁₆	14 ¹ / ₂	9 ⁷ / ₈	14 ¹ / ₂	3/8	4 ¹ / ₂	7 ¹ / ₂	27 ¹⁷ / ₃₂	
20	1	10	7 ¹ / ₄ -12	10	10.999	1	1 ¹⁵ / ₁₆	14 ¹ / ₂	9 ⁷ / ₈	14 ¹ / ₂	3/8	4 ¹ / ₂	7 ¹ / ₂	30 ¹ / ₃₂	

Table 3—Envelope and Mounting Dimensions

Table 4—Optional SAE Flange Port Pattern

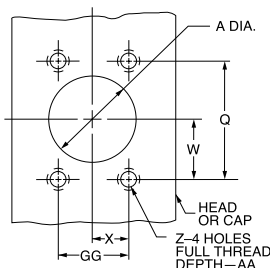

Nom. Flange Size	A	Q	GG	W	X	Z-THD UNC-2B	AA Min.	SAE
1 ¹ / ₂	1.50	2.750	1.406	1.38	0.70	1/2-13	1.06	24
2	2.00	3.062	1.688	1.53	0.84	1/2-13	1.06	32
2 ¹ / ₂	2.50	3.500	2.000	1.75	1.00	1/2-13	1.19	40
3	3.00	4.188	2.438	2.09	1.22	5/8-11	1.19	48

Table 5—Tie Rod Information

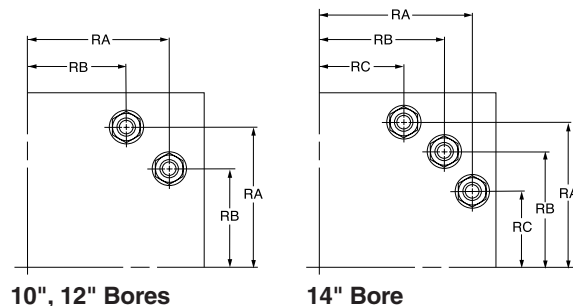

Bore	10	12	14	16	18	20
Tie Rod Thread	1 ¹ / ₈ -12	1 ¹ / ₄ -12	1 ¹ / ₄ -12	*	*	*
RA	5.291	6.270	7.485	*	*	*
RB	3.775	4.555	6.143	*	*	*
RC	—	—	4.409	*	*	*

*Consult factory for dimensions

For Cylinder Division Plant Locations – See Page II.



**Cap Rectangular and Square, Side Lug and Centerline Lug Mountings
Large Bore Sizes**

**Series 3H Large Bore
High Pressure Hydraulic Cylinders**

**Cap Rectangular Mountings
Style HH
(NFA Style ME6)**

Note: 10"-14" Bores have (4) mounting holes,
16"-20" Bores have (8) mounting holes.

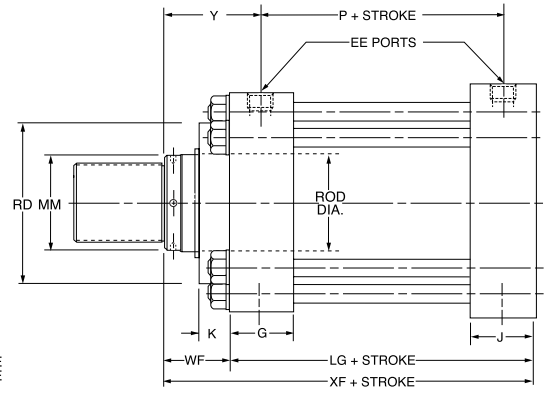
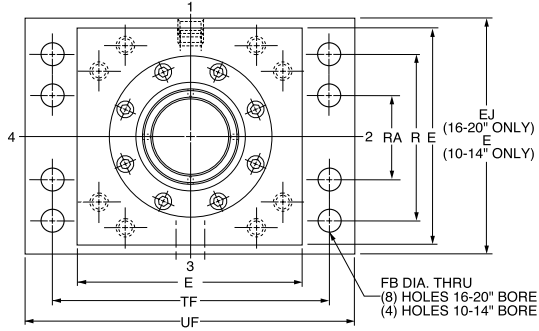
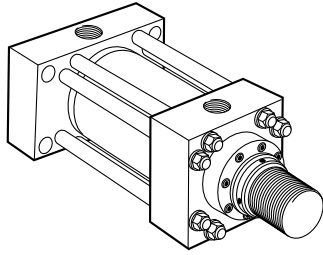

**Cap Square Flange Mounting
Style HB
(NFA Style MF6)**

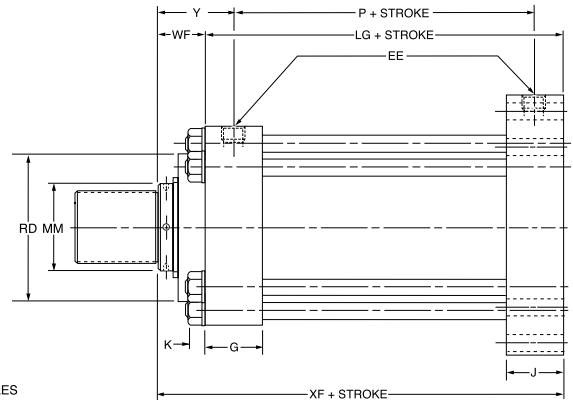
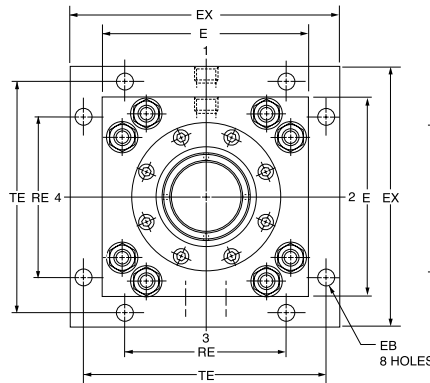
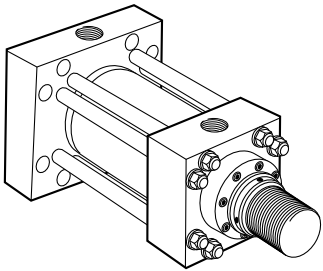

**Side Lugs Mounting
Style C
10"-14" Bore only
(NFA Style MS2)**

Note: Stroke lengths on lug mounted cylinders should not be shorter than the cylinder bore diameter. Consult factory for recommendations on shorter stroke lengths. See page 100 for further recommendations on side lug mountings.

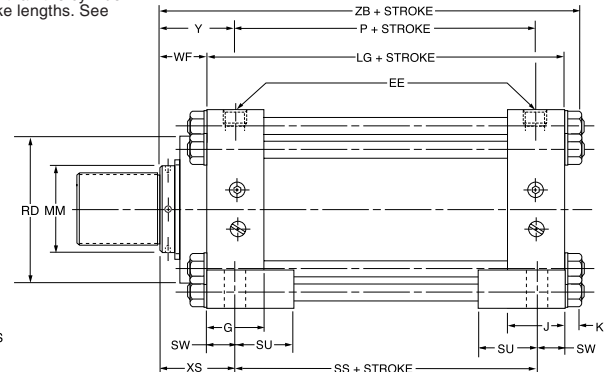
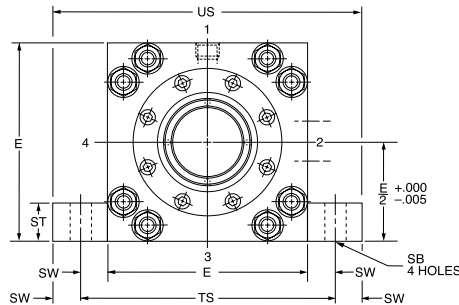
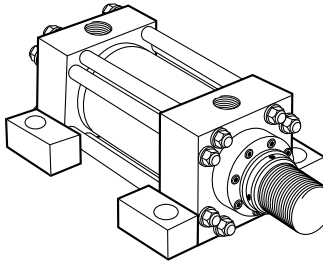

**Centerline Lugs Mounting
Style E
10"-14" Bore only
(NFA Style MS3)**

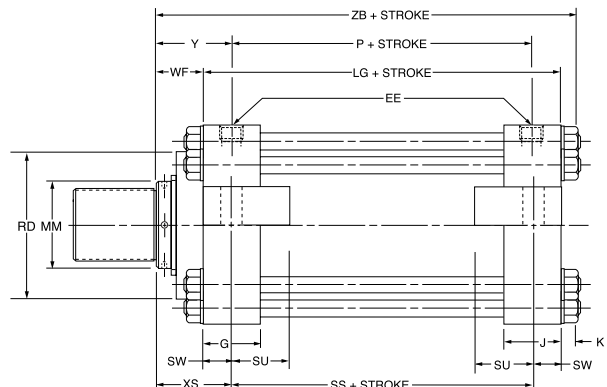
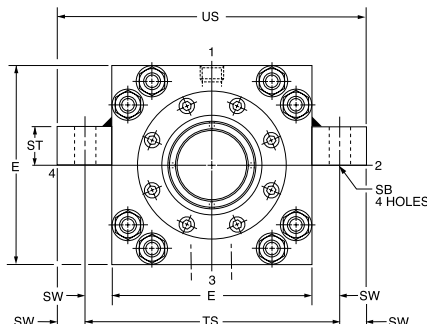
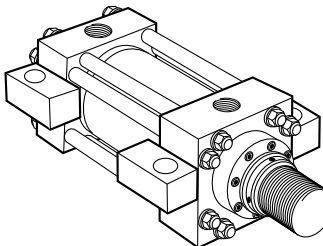

For additional information – call your local Parker Cylinder Distributor.

Series 3H Large Bore High Pressure Hydraulic Cylinders

Cap Rectangular and Square,
Side Lug and Centerline Lug
Mountings, Optional Flange Ports
Tie Rod Information

Rod End Dimensions — see table 2

Thread Style 4
(NFPA Style SM)
Small Male

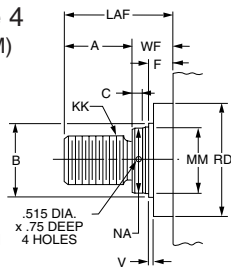

If rod end is not specified, Style 4 will be furnished.

Thread Style 9
(NFPA Style SF)
Small Female

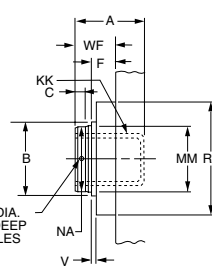

Use Style 9 for applications where female rod ends are required.

Special Thread Style 3

Special thread, extension, rod eye, blank, etc., are also available.

To order, specify "Style 3" and give desired dimensions for KK, A and LAF or WF. If otherwise special, furnish dimensional sketch.

Table 1—Envelope and Mounting Dimensions

Bore	E	EB	EE* NPTF	EE† S.A.E. FLANGE PORT	EE** S.A.E. STRAIGHT THREAD	EX	FB	G	J	K	R	RE	SB	ST	SU	SW	TE	TF	TS	UF	US	Add Stroke		
																						LG	P	SS
10	12 ⁵ / ₈	15 ¹ / ₁₆	2	2	24	16 ⁵ / ₈	11 ³ / ₁₆	31 ¹ / ₁₆	31 ¹ / ₁₆	19 ³ / ₃₂	9.62	9.89	19 ¹ / ₁₆	21 ¹ / ₄	31 ¹ / ₂	15 ⁵ / ₈	14.13	15 ⁷ / ₈	15 ⁷ / ₈	19	19 ¹ / ₈	121 ¹ / ₈	81 ¹ / ₂	87 ¹ / ₈
12	14 ⁷ / ₈	19 ¹ / ₁₆	21 ¹ / ₂	21 ¹ / ₂	24	19 ³ / ₄	21 ¹ / ₁₆	47 ¹ / ₁₆	47 ¹ / ₁₆	113 ¹ / ₃₂	11.45	11.75	19 ¹ / ₁₆	3	41 ¹ / ₄	2	16.79	181 ¹ / ₂	187 ⁷ / ₈	22	227 ⁷ / ₈	141 ¹ / ₂	101 ¹ / ₈	101 ¹ / ₂
14	17 ¹ / ₈	11 ³ / ₁₆	21 ¹ / ₂	21 ¹ / ₂	24	21 ³ / ₄	25 ¹ / ₁₆	47 ¹ / ₈	47 ¹ / ₈	113 ¹ / ₃₂	13.26	12.90	25 ¹ / ₁₆	4	43 ³ / ₄	21 ¹ / ₄	18.43	21	21 ⁵ / ₈	25	261 ¹ / ₈	155 ⁵ / ₈	107 ¹ / ₈	111 ¹ / ₈

Table 1A—Envelope and Mounting Dimensions

Bore	E	EB	EE (SAE)	EE (FLANGE)	EJ	EX	FB	G	J	K	R	RA	RE	TE	TF	UF	Add Stroke	
																	LG	P
16	19	11 ³ / ₁₆	24	3	20	241 ¹ / ₂	11 ³ / ₁₆	57 ⁷ / ₈	57 ⁷ / ₈	129 ¹ / ₃₂	151 ¹ / ₂	8	15.28	21.03	21	241 ¹ / ₂	181 ¹ / ₈	121 ¹ / ₈
18	22	21 ¹ / ₁₆	24	3	23	261 ¹ / ₂	21 ¹ / ₁₆	67 ⁷ / ₈	67 ⁷ / ₈	129 ¹ / ₃₂	18	71 ¹ / ₄	16.45	22.65	241 ¹ / ₄	281 ¹ / ₄	211 ¹ / ₈	151 ¹ / ₈
20	24	21 ¹ / ₁₆	24	3	25	29	21 ¹ / ₁₆	77 ⁷ / ₈	77 ⁷ / ₈	129 ¹ / ₃₂	20	8	18.07	24.87	261 ¹ / ₂	301 ¹ / ₂	235 ⁵ / ₈	175 ⁵ / ₈

* NPTF ports are available at an extra charge.
† Optional SAE flange ports may be specified – flange to be supplied by customer. See Table 4 for flange port pattern dimensions.
** SAE straight thread ports are standard and are indicated by port number.

Table 2—Rod Dimensions

Bore	Rod No.	Rod Dia. MM	Thread KK	Rod Extensions and Pilot Dimensions										Add Stroke			
				A	+0.000 -0.005 B	C	F	LAF	NA	RD	V	WF	Y	XS	XF	ZB	
10	1 (Std.)	41/2	31/4-12	41/2	5.249	1	115/16	77/16	43/8	81/4	1/4	215/16	43/4	49/16	151/16	1611/32	
	2	7	5-12	7	7.999	1	115/16	101/2	67/8	101/2	3/8	31/2	55/16	51/8	155/8	1629/32	
	3	5	31/2-12	5	5.749	1	115/16	83/16	47/8	87/8	1/4	33/16	5	413/16	155/16	1619/32	
12	1 (Std.)	51/2	4-12	51/2	6.249	1	115/16	811/16	53/8	93/8	1/4	33/16	5	413/16	155/16	1619/32	
	2	8	53/4-12	8	8.999	1	115/16	12	77/8	121/2	3/8	4	63/16	6	181/2	1929/32	
	3	7	5-12	7	7.999	1	115/16	101/2	67/8	101/2	3/8	31/2	511/16	51/2	18	1913/32	
14	1	7	5-12	7	7.999	1	115/16	101/2	67/8	101/2	3/8	31/2	57/8	53/4	191/8	2017/32	
	2	10	71/4-12	10	10.999	1	115/16	141/2	97/8	141/2	3/8	41/2	67/8	63/4	201/8	2117/32	
	3	8	53/4-12	8	8.999	1	115/16	12	77/8	121/2	3/8	4	63/8	61/4	195/8	2113/32	
16	1	8	53/4-12	8	8.999	1	115/16	12	77/8	121/2	3/8	4	7	*	221/8	*	
	3	9	61/2-12	9	9.999	1	115/16	131/4	87/8	131/2	3/8	41/4	71/4	*	223/8	*	
	4	10	71/4-12	10	10.999	1	115/16	141/2	97/8	141/2	3/8	41/2	71/2	*	225/8	*	
18	1	9	61/2-12	9	9.999	1	115/16	131/4	87/8	131/2	3/8	41/4	71/4	*	253/8	*	
	3	10	71/4-12	10	10.999	1	115/16	141/2	97/8	141/2	3/8	41/2	71/2	*	255/8	*	
20	1	10	71/4-12	10	10.999	1	115/16	141/2	97/8	141/2	3/8	41/2	71/2	*	281/8	*	

*Consult Factory

Table 4—Optional SAE Flange Port Pattern

Nom. Flange Size	A	Q	GG	W	X	Z-THD UNC-2B	AA Min.	SAE
1 1/2	1.50	2.750	1.406	1.38	0.70	1/2-13	1.06	24
2	2.00	3.062	1.688	1.53	0.84	1/2-13	1.06	32
2 1/2	2.50	3.500	2.000	1.75	1.00	1/2-13	1.19	40
3	3.00	4.188	2.438	2.09	1.22	5/8-11	1.19	48

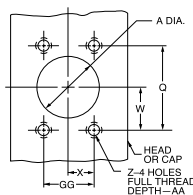
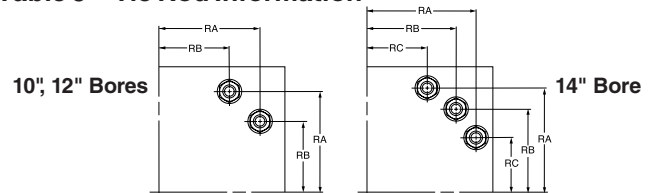

Table 5—Tie Rod Information



Bore	10	12	14	16	18	20
Tie Rod Thread	11/8-12	11/4-12	11/4-12	*	*	*
RA	5.291	6.270	7.485	*	*	*
RB	3.775	4.555	6.143	*	*	*
RC	—	—	4.409	*	*	*

*Consult factory for dimensions

For Cylinder Division Plant Locations – See Page II.



**Cap Fixed Clevis and Trunnion Mountings
Large Bore Sizes**

Series 3H Large Bore High Pressure Hydraulic Cylinders

**Cap Fixed Clevis Mountings
Style BB
(NFA Style MPI)**

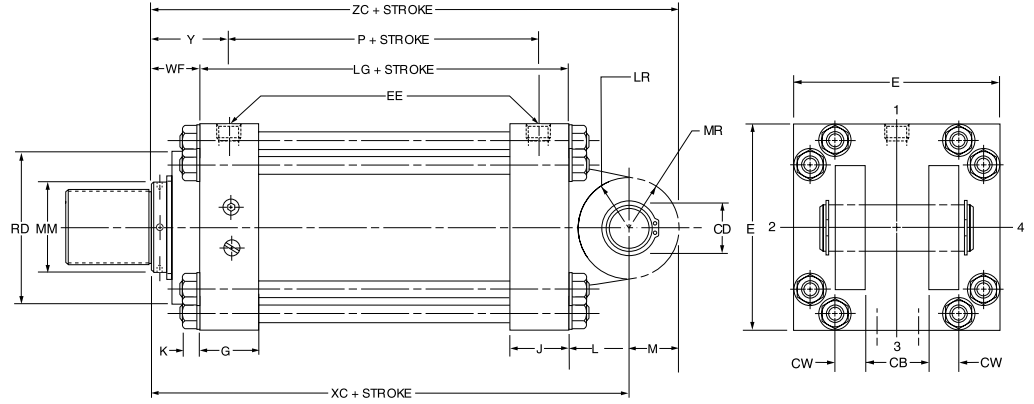
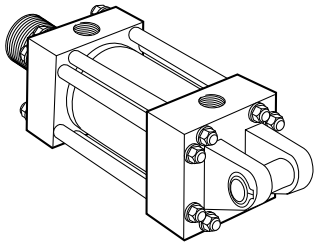

**Head Trunnion Mounting
Style D
10"-14" Bore only
(NFA Style MT1)**

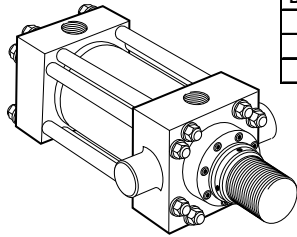

For "D" Style Mount
Maximum
Pressure
Rating - PSI

Bore	PSI
10	1600
12	1500
14	1400

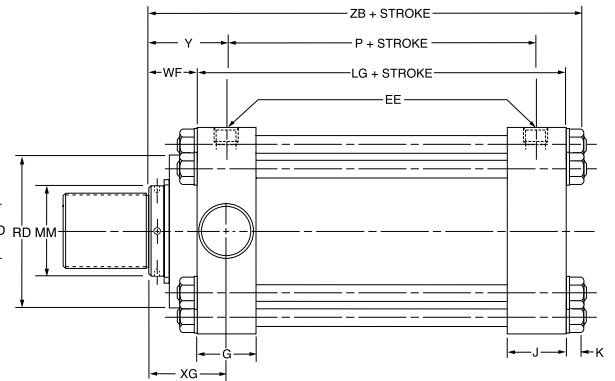
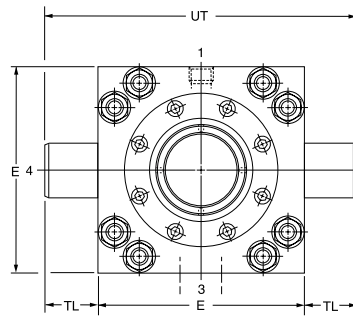

**Cap Trunnion Mounting
Style DB
10"-14" Bore only
(NFA Style MT2)**

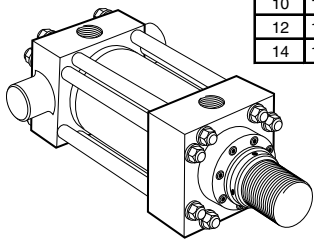

For "DB" Style Mount
Maximum
Pressure
Rating - PSI

Bore	PSI
10	1600
12	1500
14	1400

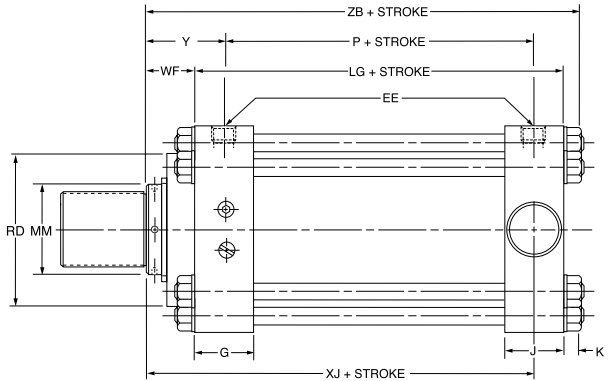
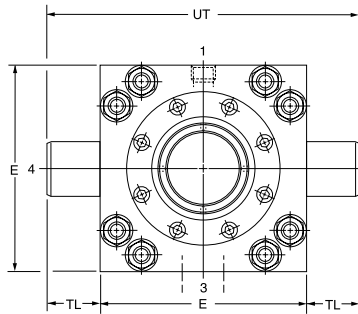

**Intermediate Fixed Trunnion Mounting
Style DD
(NFA Style MT4)**

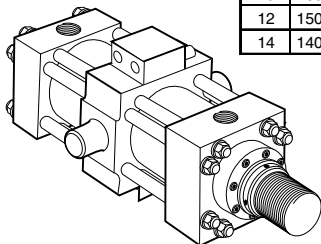

For "DD" Style Mount
Maximum
Pressure
Rating - PSI

Bore	PSI
10	1600
12	1500
14	1400

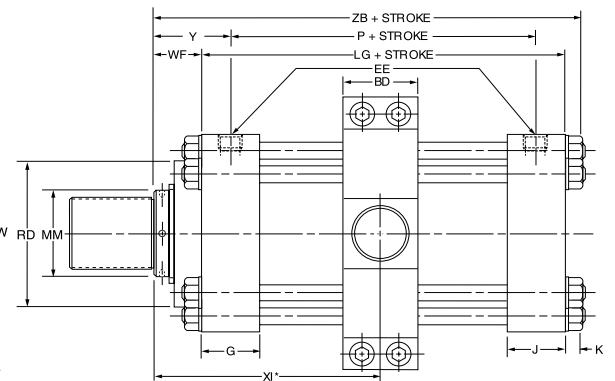
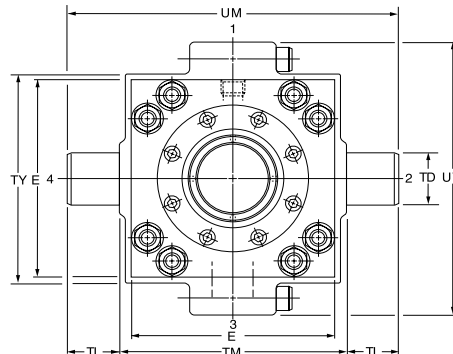

For additional information – call your local Parker Cylinder Distributor.

Series 3H Large Bore High Pressure Hydraulic Cylinders

Cap Fixed Clevis and Trunnion Mountings/Optional Flange Ports Tie Rod Information Large Bore Sizes

Rod End Dimensions — see table 2

Thread Style 4
(NFPA Style SM)
Small Male

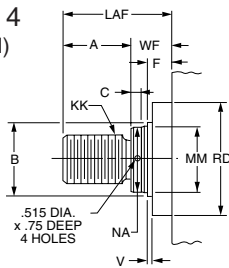

If rod end is not specified, Style 4 will be furnished.

Thread Style 9
(NFPA Style SF)
Small Female

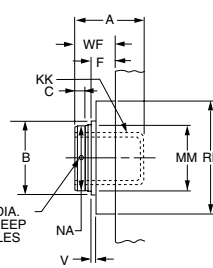

Use Style 9 for applications where female rod ends are required.

Special Thread Style 3

Special thread, extension, rod eye, blank, etc., are also available.

To order, specify "Style 3" and give desired dimensions for KK, A and LAF or WF. If otherwise special, furnish dimensional sketch.

Table 1—Envelope and Mounting Dimensions

Bore	BD	CB	+0.001 -.003 CD	CW	E	EE* NPTF	EE† S.A.E. FLANGE PORT	EE** S.A.E. STRAIGHT THREAD	G	J	K	L	LR	M	MR	+0.000 -.001 TD	TL	TM	TY	UM	UT	UW	LG	P	Add Stroke
10	4 1/2	4	3.500	2	12 5/8	2	2	24	3 11/16	3 11/16	19/32	4	3 3/8	3 1/2	3 1/2	3.500	3 1/2	14	13	21	19 5/8	17 1/2	12 1/8	8 1/2	
12	5 1/2	4 1/2	4.000	2 1/4	14 7/8	2 1/2	2 1/2	24	4 7/16	4 7/16	1 13/32	4 1/2	3 7/8	4	4	4.000	4	16 1/2	15 1/2	24 1/2	22 7/8	20 3/4	14 1/2	10 1/8	
14	5 1/2	6	5.000	3	17 1/8	2 1/2	2 1/2	24	4 7/8	4 7/8	1 13/32	5 3/4	4 3/16	5	5	4.500	4 1/2	19 1/2	19 1/4	28 1/2	26 1/8	24 3/4	15 5/8	10 7/8	

Table 1A—Envelope and Mounting Dimensions (Style BB only)

Bore	E	EE (SAE)	EE (FLANGE)	CB	CD	CW	G	J	K	L	LR	M	MD	MR	LG	P	Add Stroke
16	19	24	3	7	6	3 1/2	5 7/8	5 7/8	12 9/32	7	6 1/4	6	16	6	18 1/8	12 1/8	
18	22	24	3	8	6 1/2	4	6 7/8	6 7/8	12 9/32	7 5/8	6 3/4	6 1/2	18	6 1/2	21 1/8	15 1/8	
20	24	24	3	9	7 1/2	4 1/2	7 7/8	7 7/8	12 9/32	8 3/4	7 3/4	7 1/2	20	7 1/2	23 5/8	17 5/8	

* NPTF ports are available at an extra charge.
† Optional SAE flange ports may be specified — flange to be supplied by customer. See Table 4 for flange port pattern dimensions.
** SAE straight thread ports are standard and are indicated by port number.
Dimension CD is pin diameter.

Table 2—Rod Dimensions

Bore	Rod No.	Rod Dia. MM	Thread KK	Rod Extensions and Pilot Dimensions											Add Stroke								
				A	+0.000 -.005 B	C	F	LAF	NA	RD	V	WF	XG	Min. XI*	Y	XC	XJ	ZB	ZC				
10	1 (Std.)	4 1/2	3 1/4-12	4 1/2	5.249	1	1 15/16	7 7/16	4 3/8	8 1/4	1/4	2 15/16	4 3/4	9 1/16	4 3/4	19 1/16	13 3/8	16 11/32	22 9/16				
	2	7	5-12	7	7.999	1	1 15/16	10 1/2	6 7/8	10 1/2	3/8	3 1/2	5 5/16	9 5/8	5 5/16	19 5/8	13 15/16	16 29/32	23 1/8				
	3	5	3 1/2-12	5	5.749	1	1 15/16	8 3/16	4 7/8	8 7/8	1/4	3 3/16	5	9 5/16	5	19 5/16	13 5/8	16 19/32	22 13/16				
	4	5 1/2	4-12	5 1/2	6.249	1	1 15/16	8 11/16	5 3/8	9 3/8	1/4	3 3/16	5	9 5/16	5	19 5/16	13 5/8	16 19/32	22 13/16				
12	1 (Std.)	5 1/2	4-12	5 1/2	6.249	1	1 15/16	8 11/16	5 3/8	9 3/8	1/4	3 3/16	5 3/8	10 5/8	5 3/8	22 3/16	15 1/2	19 3/32	26 3/16				
	2	8	5 3/4-12	8	8.999	1	1 15/16	12	7 7/8	12 1/2	3/8	4	6 3/16	11 1/2	6 3/16	23	16 5/16	19 29/32	27				
	3	7	5-12	7	7.999	1	1 15/16	10 1/2	6 7/8	10 1/2	3/8	3 1/2	5 11/16	10 15/16	5 11/16	22 1/2	15 13/16	19 13/32	26 1/2				
14	1	7	5-12	7	7.999	1	1 15/16	10 1/2	6 7/8	10 1/2	3/8	3 1/2	5 15/16	11 7/16	5 7/8	24 7/8	16 11/16	20 17/32	29 7/8				
	2	10	7 1/4-12	10	10.999	1	1 15/16	14 1/2	9 7/8	14 1/2	3/8	4 1/2	6 15/16	12 7/16	6 7/8	25 7/8	17 11/16	21 17/32	30 7/8				
	3	8	5 3/4-12	8	8.999	1	1 15/16	12	7 7/8	12 1/2	3/8	4	6 7/16	11 15/16	6 3/8	25 3/8	17 3/16	21 1/32	30 3/8				
16	1	8	5 3/4-12	8	8.999	1	1 15/16	12	7 7/8	12 1/2	3/8	4	**	**	7	29 1/8	**	**	35 1/8				
	3	9	6 1/2-12	9	9.999	1	1 15/16	13 1/4	8 7/8	13 1/2	3/8	4 1/4	**	**	7 1/4	29 3/8	**	**	35 3/8				
	4	10	7 1/4-12	10	10.999	1	1 15/16	14 1/2	9 7/8	14 1/2	3/8	4 1/2	**	**	7 1/2	29 5/8	**	**	35 5/8				
18	1	9	6 1/2-12	9	9.999	1	1 15/16	13 1/4	8 7/8	13 1/2	3/8	4 1/4	**	**	7 1/4	33	**	**	39 1/2				
	3	10	7 1/4-12	10	10.999	1	1 15/16	14 1/2	9 7/8	14 1/2	3/8	4 1/2	**	**	7 1/2	33 1/4	**	**	39 3/4				
20	1	10	7 1/4-12	10	10.999	1	1 15/16	14 1/2	9 7/8	14 1/2	3/8	4 1/2	**	**	7 1/2	36 7/8	**	**	44 3/8				

* Dimension XI to be specified by customer. **Consult Factory.

Table 4—Optional SAE
Flange Port Pattern

Nom. Flange Size	A	Q	GG	W	X	Z-THD UNC-2B	AA Min.	SAE
1 1/2	1.50	2.750	1.406	1.38	0.70	1/2-13	1.06	24
2	2.00	3.062	1.688	1.53	0.84	1/2-13	1.06	32
2 1/2	2.50	3.500	2.000	1.75	1.00	1/2-13	1.19	40
3	3.00	4.188	2.438	2.09	1.22	5/8-11	1.19	48

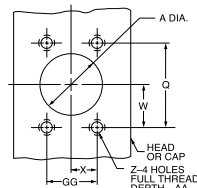

Table 5—Tie Rod Information

Bore	10	12	14	16	18	20
Tie Rod Thread	1 1/8-12	1 1/4-12	1 1/4-12	*	*	*
RA	5.291	6.270	7.485	*	*	*
RB	3.775	4.555	6.143	*	*	*
RC	—	—	4.409	*	*	*

*Consult factory for dimensions

For Cylinder Division Plant Locations — See Page II.

How to Use Double Rod Cylinder Dimensioned Drawings

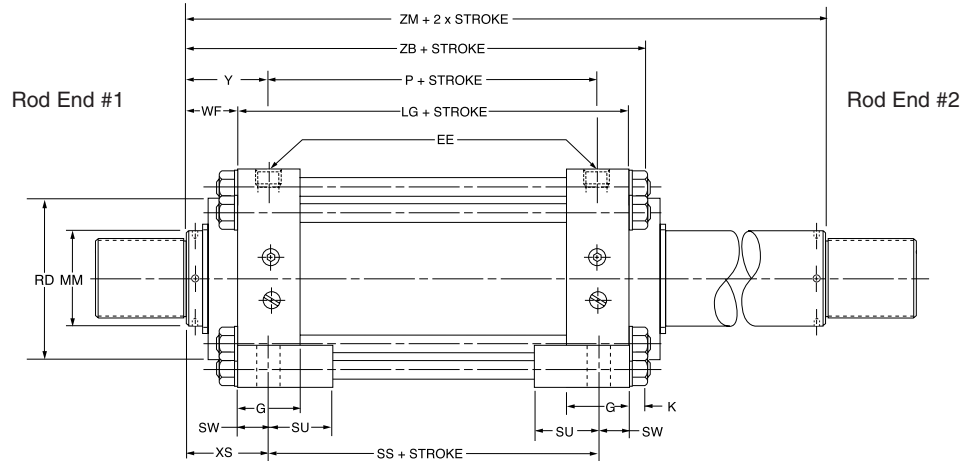
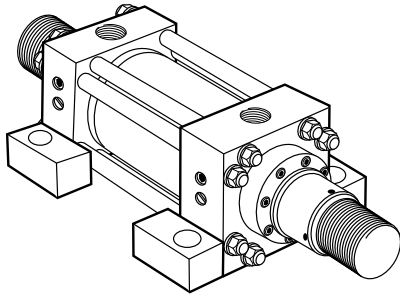

Mounting Styles for Single Rod Models	Mounting Styles for Corresponding Double Rod Models*	Dimension Shown on This Page Supplement Dimensions on Pages Listed Below
T	K	92
TB	KTB	92
TD	KTD	92
JJ	KJJ	94
JB	KJB	94
C	KC	96
E	KE	96
D	KD	98
DD‡	KDD	98

*If only one end of these Double Rod Cylinders is to be cushioned, be sure to specify clearly which end this will be.

‡Specify XI dimension from rod end #1.

To obtain dimensioning information on a double rod cylinder, first select the desired mounting style and refer to the corresponding single rod cylinder model shown on the preceding pages. (See table at left.) After you have determined all necessary dimensions from that drawing, turn back to this page and supplement those dimensions with additional ones from the drawing above and table at right. These added dimensions differ from, or are in addition to, those shown on the preceding pages and provide the additional information needed to completely dimension a double rod cylinder model.

On a double rod cylinder where the two rod ends are different, be sure to clearly state which rod end is to be assembled at which end. Port position 1 is standard. If other than standard, specify pos. 2, 3 or 4 when viewed from rod end #1 only. See port position information in Section C.

Bore	Rod Code	Rod Dia.	Add 2X Stroke ZM
10	1	4 1/2	18
	2	7	19 1/8
	3	5	18 1/2
	4	5 1/2	18 1/2
12	1	5 1/2	20 7/8
	2	8	22 1/2
	3	7	21 1/2
14	1	7	22 5/8
	2	10	24 5/8
	3	8	23 5/8
16	1	8	26 1/8
	3	9	26 5/8
	4	10	27 1/8
18	1	9	29 5/8
	3	10	30 1/8
20	1	10	32 5/8

Mounting Recommendations and Other Mountings

In addition to the standard mountings dimensioned on the preceding pages, the following information covers mounting ideas that may prove helpful in your applications. When needed, special heads, caps, and flanges can be provided. Sketches of your requirements, together with specifications relative to the application and forces involved should be submitted.

Mounting Bolts — High tensile socket head screws are recommended for all mounting styles. Use 1/16" smaller than hole size.

Flange Mountings — Cylinders can be properly centered by measuring from piston rod diameter. After mounting the flange may be drilled for pins or dowels to prevent shifting.

Side Lug Mountings — Caution, cylinders which do not absorb force on their centerline (Group 3) tend to sway when under load. Short stroke, non-centerline mounted cylinders can subject mounting bolts to large tension forces which when combined with shear forces can overstress standard mounting bolts. Side lug mounted cylinders should always be prevented from shifting through use of shear keys so located as to resist the major load, whether push or pull.

Trunnion Mountings — Cylinders require lubricated pillow blocks with minimum bearing clearances. Pillow blocks should be carefully aligned and rigidly mounted so the trunnions will not be subjected to bending moments. The rod end connection should also be pivoted, with the customer's pin in the piston rod knuckle parallel to the trunnions.

Clevis Mountings — Cylinders should be pivoted at both ends, with the customer's pin in the piston rod knuckle parallel to the pivot pin supplied with the clevis.

Metallic Rod Wiper

When specified, metallic rod wipers can be supplied at extra cost, instead of the standard synthetic rubber wiperseal. Recommended in applications where atmospheric particles or splashing tend to cling to the extended piston rod and otherwise damage the synthetic rubber wiperseal. Installation of metallic rod wiper does not affect cylinder dimensions.

For additional information – call your local Parker Cylinder Distributor.

Notes

B

For Cylinder Division Plant Locations – See Page II.

Series 3H Large Bore High Pressure Hydraulic Cylinders

How to Order

How to Order Series “3H” Cylinders

When ordering Series 3H cylinders, please review the following:

Note: Duplicate cylinders can be ordered by giving the SERIAL NUMBER from the nameplate of the original cylinder. Factory records supply a quick positive identification.

Piston Rods: Specify rod code number based on diameter. Give thread style number for a standard thread or specify dimensions. See “Style 3 Rod End” below.

Cushions: If cushions are required specify according to the model number on the next page. If the cylinder is to have a double rod and only one cushion is required, be sure to specify clearly which end of the cylinder is to be cushioned.

Special Modifications: Additional information is required on orders for cylinders with special modifications. This is best handled with descriptive notes. For further information, consult factory.

Water Service Modifications

Standard – When requested, Parker can supply Series 3H cylinders with standard modifications that make the cylinders more nearly suitable for use with water as the fluid medium. The modifications include chrome-plated cylinder bore; electroless nickel-plated, non-wearing internal surfaces; Lipseal style piston, Buna N Seals and chrome-plated, stainless steel piston rod. On orders for water service cylinders, be sure to specify the maximum operating pressure.

Class 1 Seals

Class 1 seals are the seals provided as standard in a cylinder assembly unless otherwise specified. For further information on fluid compatibility or operating limitations of all components, see section C.

For the 3H series cylinders the following make-up Class 1 Seals:

- Primary Piston Rod Seal – Nitrile
- Piston Rod Wiper – Nitrile

Combination Mountings

Single Rod End The first mounting is the one called out on the head end of the cylinder. The second or subsequent mountings are called out as they appear in the assembly moving away from the rod end. Exception: When tie rod mountings are part of a combination, the model number should contain an “S” (Special) in the model code and a note in the body of the order clarifying the mounting arrangement. The “P” is used to define a thrust key and is not considered to be a mounting. However, it is located at the primary end.

Example: 10.00 CCB3HLTS14AC x 10.000

Combination “C” mounting head only. “BB” mounting cap end
This cylinder is also cushioned at both ends.

Double Rod End In general, the model number is read left to right corresponding to the cylinder as viewed from left to right with the

Style 3 Rod End

A style 3 rod end indicates a special rod end configuration. All special piston rod dimensions must have **all three:** KK; A; W/WF or LA/LAF specified with the rod fully retracted. A sketch or drawing should be submitted for rod ends requiring special machining such as snap ring grooves, keyways, tapers, multiple diameters, etc. It is good design practice to have this machining done on a diameter at least 0.065 inches smaller than the piston rod diameter. This allows the piston rod to have a chamfer preventing rod seal damage during assembly or

Service Policy

On cylinders returned to the factory for repairs, it is standard policy for the Cylinder Division to make such part replacements as will put the cylinder in as good as new condition. Should the condition of the returned cylinder be such that expenses for repair would exceed the costs of a new one, you will be notified.

Address all correspondence and make shipments to, Service Department at your nearest regional plant listed in the pages of this catalog.

Additional Lipseal® Piston (if desired): Parker Lipseal® pistons are offered as an option at no extra cost in the Series 3H cylinders. With this feature, zero leakage under static holding conditions is attained. Call out “with Lipseal piston” if this type of piston is desired. If not specified, the Hi Load piston seals will be furnished.

Fluid Medium: Series 3H hydraulic cylinders are equipped with seals for use with hydraulic oil. If other than hydraulic oil will be used, specify class of fluid (See Catalog section C.)

(These factors must be taken into account because of the lower tensile strength of stainless steels available for use in piston rods.)

Warranty— Parker will warrant Series 3H cylinders modified for water service to be free of defects in materials or workmanship. On the other hand, Parker cannot accept responsibility for premature failure of cylinder function, where failure is caused by corrosion, electrolysis or mineral deposits within the cylinder.

Piston Seals – Hi-Load. Filled PTFE seals with a nitrile expander
Option – Cast Iron Rings

O-Rings – Nitrile (nitrile back-up washer when used)

Additional data is required on orders for cylinders with special modifications. For further information, consult factory.

primary end at rod end #1. See Double Rod Models information page in this section. For this option the piston rod number, piston rod end, and piston rod threads are to be specified for both ends. The simplest are for symmetric cylinders such as: TD, C, E, F, G, and CB mounts. All other mounting styles, the description of the first rod end will be at the mounting end. In the case of multiple mounts, the description of the first rod end will be at the primary mounting end. For “DD” mounts, the description of the first rod end will be the same location as the “XI” dimension.

Example: 10.00 KDD3HLT24A/18A x 10.000 XI=10.00

This is a center trunnion mounting cylinder with the XI dimension measured from the code 2 rod side of the cylinder which has the style 4 thread. The opposite end code 1 rod with the style 8 thread.

assembly or maintenance. Standard style 55 rod ends with a longer than standard WG dimension should call out a style 3 rod end and the note: **same as 55 except WG=_____**. A drawing should be submitted for special 55 rod ends that have specific tolerances or special radii. Special rod ends that have smaller than standard male threads, larger than standard female threads, or style 55 rod ends with smaller than standard AF or AE dimensions are to be reviewed by Engineering for proper strength at operating pressure.

Certified Dimensions

Parker Cylinder Division guarantees that all cylinders ordered from this catalog will be built to dimensions shown. All dimensions are certified to be correct, and thus it is not necessary to request certified drawings.

For additional information – call your local Parker Cylinder Distributor.

Series 3H Large Bore High Pressure Hydraulic Cylinders

Model Numbers
Large Bore Sizes

Series 3H Model Numbers – How to Develop Them – How to “Decode” Them

Parker Series 3H cylinders can be completely and accurately described by a model number consisting of coded symbols. To develop a model number, select only those symbols that represent the cylinder required, and place them in the sequence indicated below.

Feature	Description	Page No.	Symbol	
Bore*	Specify in inches			10" C K C JB 3H K T V S 1 4 A C 12"
Cushion-Head	Used only if cushion required	C94, 90	C	↑
Double-Rod	Used only if double-rod cylinder is required	100	K	↑
Mounting* Style	Tie Rods Extended Head End (10"-14" Bore)	92	TB	↑
	Tie Rods Extended Cap End (10"-14" Bore)	92	TC	↑
	Tie Rods Extended Both Ends (10"-14" Bore)	92	TD	↑
	Head Square Flange	94	JB	↑
	Head Rectangular	94	JJ	↑
	Cap Square Flange	96	HB	↑
	Cap Rectangular	96	HH	↑
	Side Lugs (10"-14" Bore)	96	C†	↑
	Centerline Lugs (10"-14" Bore)	96	E	↑
	Cap Fixed Clevis	98	BB	↑
	Head Trunnion (10"-14" Bore)	98	D	↑
	Cap Trunnion (10"-14" Bore)	98	DB	↑
	Intermediate Fixed Trunnion‡	98	DD	↑
Combination Mounting Style	Any Practical Mounting Style Listed Above	–	As listed above	↑
Series*	Used in all 3H Model Numbers	–	3H	↑
Piston	Hi-Load Piston standard	B89, C4	K	↑
	Used only for Ring Packed Piston	B88	C	↑
Ports*	SAE Straight Thread O-Ring Port (Standard)	C89	T	↑
	Used only for NPTF (Dry Seal Pipe Thread) (10"-14" Bore Only)	C89	U	↑
	Used only for BSP (Parallel Thread ISO 228)	C89	R	↑
	Used only for SAE Flange Ports (3000 psi)	C89	P	↑
	Used only for BSPT (Taper Thread)	C89	B	↑
	Used only for Metric Thread	C89	G	↑
	Used only for Metric Thread per ISO 6149	C89	Y	↑
Common Modifications	Fluorocarbon Seals	C83	V	↑
	Water Service	C83	W	↑
Special Modifications	Used only if special Modifications are required:			
	Port Position Change	C119	S	↑
	Special Seals	C83		
	Stop Tube*	C95,C122		
Piston Rod* Number	For Single Rod Cylinders, select one only.	–	1	↑
	Refer to Rod number listing, Table 2, Pages 90 through 97	–	2	↑
		–	3	↑
Piston* Rod End	Select:			
	Style 4 Small Male	C92	4	↑
	Style 8 Intermediate Female		8	↑
	Style 9 Short Female		9	↑
	Style 55 Rod End for Flange Coupling		55	↑
	Style 3 Special (Specify)		3	↑
Piston Rod* Threads	UNF Standard	C92	A	↑
	BSF (British Fine)		W	↑
	Metric		M	↑
Cushion-Cap	Used only if cushion required	C94, 90	C	↑
Stroke**	Specify in inches	C122	–	↑

†Cylinders with this mounting style should have a minimum stroke length of equal to or greater than its bore diameter.

**See chart in Section C for minimum piston rod diameter.

‡Specify XI dimension

*Required for Basic Cylinder Model Number

•In case of Stop Tube, call out Gross Stroke

For Cylinder Division Plant Locations – See Page II.



Parker TS-2000 seal designed to eliminate cylinder rod seal leakage.

Parker Series 2H Heavy Duty and Series 3L Medium Duty Hydraulic Cylinders with the TS-2000 seal offers positive protection against cylinder rod leakage under the most demanding applications.

The TS-2000 seal is the product of countless hours of research, development and extensive field testing and is only available on Parker Cylinders.

Based on the popular Parker Serrated Lipseal rod design, the TS-2000 incorporates the pressure-compensated, uni-directional characteristics of a U-cup with the multiple edge sealing effectiveness of compression-type stacked-packings.

The goal for the Parker team was to design a rod seal suitable for all types of applications, regardless of pressure profile. It had to be composed of a

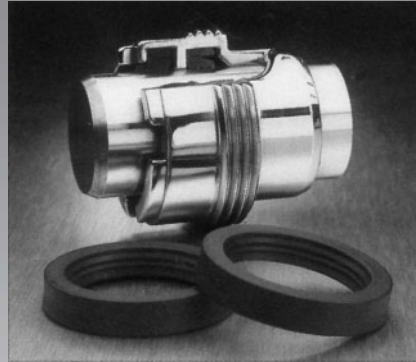

“Jewel” gland with wiperseal and TS-2000 cylinder rod seal.

material that would not react chemically with hydraulic fluids. And it had to produce better and more reliable “dry rod” performance than the standard serrated lip-seal design in a broad range of applications.

The result is the TS-2000 seal, designed especially to eliminate rod seal leakage in the most demanding applications. It features a special polyurethane material that will not react chemically with petroleum-based hydraulic fluid, is extremely resistant to abrasion and extrusion, and provides exceptional service life. It has more sealing edges than other seals on the

market, which in turn produces “dry rod” performance. The seal geometry was refined for maximum stability in the groove and has excellent performance characteristics throughout a broad range of pressures and piston rod velocities.

The Parker design team was successful!

TS-2000 rod seal has not failed in any of the test applications in the lab or on the job, no matter how tough or demanding.

For more information on the TS-2000 call or write your local Parker distributor or Parker Hannifin Corporation, Cylinder Division, 500 S. Wolf Road, Des Plaines, IL 60016, 847-298-2400.

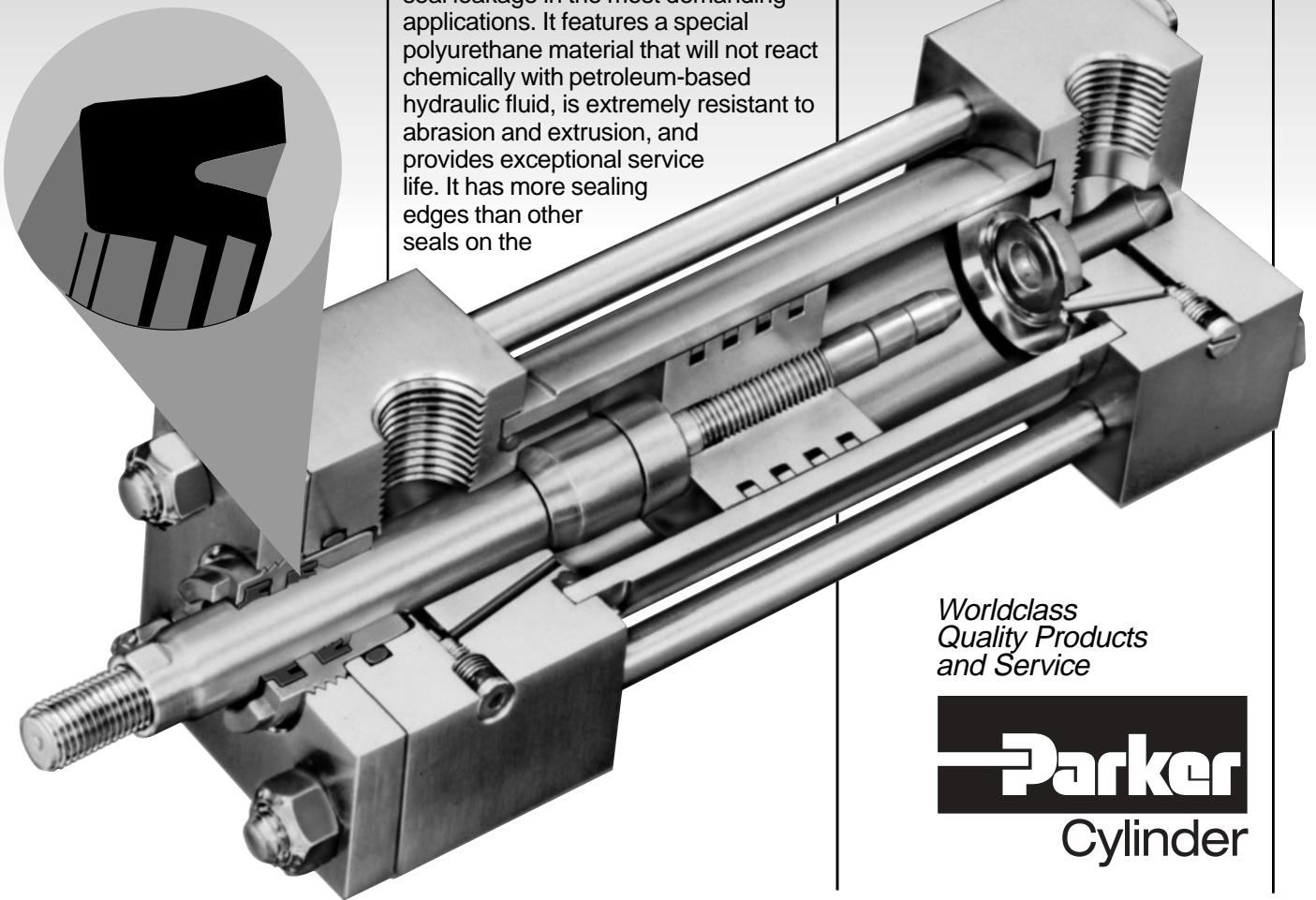

*Worldclass
Quality Products
and Service*

Parker
Cylinder

For additional information – call your local Parker Cylinder Distributor.